

PT

外螺纹焊钉 Threaded Stud



低碳钢 Steel



不锈钢 Stainless steel

d1	d3	d4	l3	h	nmax	±1°
M3	4.50	0.60	0.55	0.7-1.4	1.50	3°
M4	5.50	0.65	0.55	0.7-1.4	1.50	3°
M5	6.50	0.75	0.80	0.8-1.4	2.00	3°
M6	7.50	0.75	0.80	0.8-1.4	2.00	3°
M8	9.00	0.75	0.85	0.8-1.4	3.00	3°
M10	10.50	0.80	0.90	0.8-1.4	3.00	3°

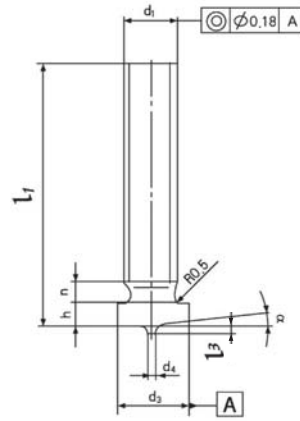

焊接前
Before welding

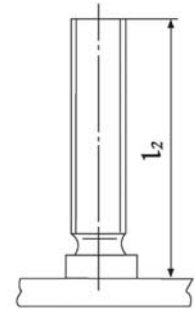

焊接后
After welding

UT

无螺纹焊钉 Unthreaded Stud



低碳钢 Steel



不锈钢 Stainless steel

d1	d3	d4	l3	h	α ±1°
3	4.50	0.60	0.55	0.7-1.4	3°
4	5.50	0.65	0.55	0.7-1.4	3°
5	6.50	0.75	0.80	0.7-1.4	3°
6	7.50	0.75	0.80	0.7-1.4	3°

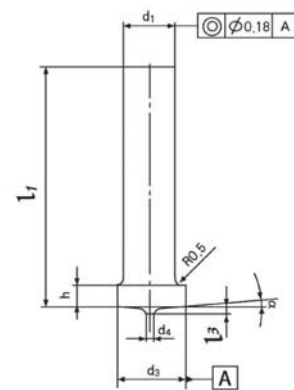

焊接前
Before welding

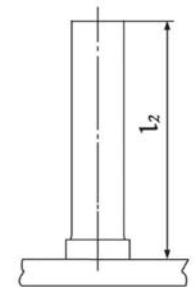

焊接后
After welding

Blind Rivet Nuts

Blind Rivets

Self-Chinching

Weld Studs

Rivet tools

IT

内螺纹焊钉 Stud With Internal Thread



低碳钢 Steel



不锈钢 Stainless steel

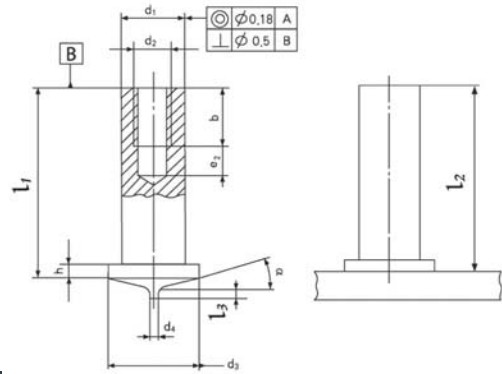

焊接前
Before welding

焊接后
After welding

d1	d2	b	e2min	d3	d4	L3	h	$\alpha \pm 1^\circ$
5	M3	4.50	2.50	6.50	0.75	0.80	0.7-1.4	3°
6	M4	6.00	3.00	7.50	0.75	0.80	0.7-1.4	3°
7.1	M5	7.50	3.00	9.00	0.75	0.85	0.8-1.4	3°

PD

拉弧焊钉 Threaded Stud



低碳钢 Steel



不锈钢 Stainless steel

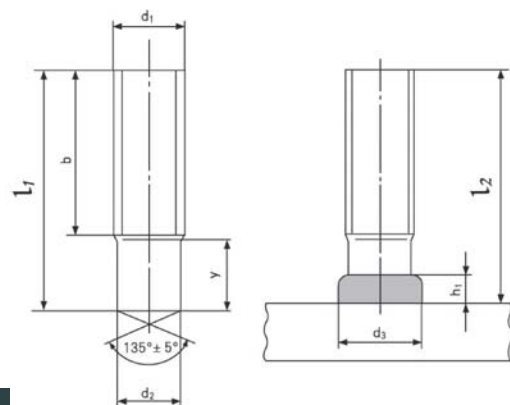

焊接前
Before welding

焊接后
After welding

d1	M6	M8	M10	M12	M16	M20	M24
d2	5.35	7.19	9.03	10.86	14.70	18.38	22.05
d3	8.50	10.00	12.50	15.50	19.50	24.50	30.00
h1	3.50	3.50	4.00	4.50	6.00	7.00	10.00
ymin	9.00	9.00	9.50	11.50	13.50	15.50	30.00